



The



Script



Volume 65, 3 – Santa Clara Valley Chapter of the Model A Ford Club of America – March 2024



*Happy
St. Patrick's Day!*

HERE'S TO THE LAND OF THE SHAMROCK SO GREEN.

HERE'S TO EACH LAD AND HIS DARLIN' COLLEEN.

MAY YOUR TROUBLES BE LESS, AND YOUR BLESSINGS BE MORE.

AND NOTHING BUT HAPPINESS COME THROUGH YOUR DOOR.

March Presidents Message As I write this, the CCRG is a short week away. I can't believe it's March already. At the last count there are 22 SCVC families driving out to Clovis. The only club with more registrations is the host club, the Sierra A's having 36 entries. I'm looking forward to a nice weekend out in the valley with my fellow members and having fun too. There should be lots of blossoms on the trees that will be beautiful to drive through.

Thank you to Rob and Christine Barnard for opening their home for the lunch stop on the February SCVC Birthday and Backroads Tour. The day turned out to be a beautiful day between days of rain storms with the cake being good too. Your club president has arranged to do the Presidents Tour for lunch in mid August. There will be more details as they get ironed out.

The SCVC Fun and Fashion leaders are really trying to inspire interest in era fashions. Past seminars have included shoes and dresses with furs, hats, jewelry and more slated for later this spring and summer. Thanks to Nora Elderton, Helen Christensen, Judy Rinaldi, Jill Barrett and Laurie Elliott for their efforts. Rich Campbell, Don Cole and John Seabury helped make sense of measuring tools in the February seminar that perform in

hundredths and thousandths of an inch. Thanks guys!

Let's talk credit cards. I jumped the gun by mentioning a survey to gauge interest in paying membership dues and such. While the board considers this a good idea, we don't think this is the right time despite how much interest there might be. We don't want to add to the jobs of the treasurer and membership directors when we have a difficult time getting volunteers to fill those and other board positions. Thanks to Larry Rosenthal, Doug Anberg and Wayne Innamorato for their time and energy in dissecting all the different options.

Let's go out and drive! Thanks, Mark



ABOUT THE NEWSLETTER

The Ford Script is published monthly by the Santa Clara Valley Chapter of the Model A Ford Club of America, P.O. Box 6918, San Jose, CA 95150. This newsletter is to aid in the restoration and enjoyment of the Model A Ford automobile and keep club members informed of events and activities. All members are encouraged to submit articles of interest. Permission is granted to other publications to copy material, provided that acknowledgment is given. E-mail, mail or deliver all newsletter items to the editor by the end of the monthly general meeting for inclusion in The Ford Script. All correspondence concerning The Ford Script can be sent directly to the editor; suggestions, photos, write-ups and articles are welcome. E-mail: editor.scvcma@gmail.com.

Membership: For 2024, membership in SCVC is \$35 per year, per family.

Membership applications are available at www.scvcma.org. Membership in MAFCA is a prerequisite for membership in SCVC. Send \$50 MAFCA dues to Model A Ford Club of America, 250 S. Cypress St., La Habra, CA 90631-5515 or join on the website: www.mafca.com

IN THIS ISSUE

President's Message.....page 2
Meeting Minutes.....Page 3
Coming Attractions.....Page 5
SCVC Birthday Tour..... Page 7
Member Model A Story.....Page 8
TechSeminar.....Page 9
Fun/Fashion Seminar.....Page 10
MAFFI Minute.....Page 12
MAFCA President Message.....Page 13
Tech Corner.....Page 14
Patents by Chuck.....Page 15
Remember When.....Page 16
Miscellaneous..... Page 17
Classified Ads.....Page 18
Support Our Advertisers Page 20

President:	Mark Barrett	(408) 371-7553	H
Vice President:	Mike Stevens	(408) 621-0137	C
Secretary:	Lizanne Polland	(408) 410-7074	C
Treasurer:	Doug Anberg	(408) 981-9999	C
Membership:	John Seabury	(530) 304-2833	C
Activities:	Dave & Susan Jones	(650) 793-2778	C
Editors:	Bob & Patti Meneely	(650) 948-9301	C

GENERAL MEETING MINUTES 2/6/2024

Minutes from the General Meeting on March 5, 2024 by Lizanne [Leezohn] Polland

The meeting was called to order at 7pm by President Mark Barrett. Gina Anderson led the flag salute. 57 families/101 chairs were in attendance

Rich Lange: If you are having trouble with the Zoom invitation link (new each month) in the email, try copying and pasting the link into the browser. Otherwise, contact Rich.

Greeter: Susan Colbeck no new guests.

Newcomers: Jay Day welcomed and encouraged us to participate in club seminars, tours, ice cream socials and ... most importantly to get our A's on the road.

President: Mark Barrett identified a destination for the President's tour of Aug 17th - at John McAlpine's residence in Aptos.

Secretary: [Leezohn] Polland. No corrections to the February minutes as printed. A motion was made by Jay Day, seconded by Mary Beaman. Correspondence: Five annual membership renewal checks and a bank statement from Washington Federal Bank (WaFd Bank). Luther Bank was acquired by WaFd Bank.

Vice President: Mike Stevens has more important news than voting; of significance, Prince Edward met with a 192 year old tortoise this past month. His mother, Queen Elizabeth, met with the same tortoise in 1947. He had other anecdotes for us.

Treasurer: Doug Anberg reported our income and expenses.

Editors: Bob and Patti Meneely thank those who submitted articles this month. The Mar Script is ready and awaiting just the minutes. Please keep sending in articles for next month.

Membership: John Seabury reported we had 115 member families in 2023. Today 100 member families have

renewed - 15 families have not renewed. John will send out a 30 day grace period around Mar 8th. A \$10 penalty will occur for those who let their membership expire. John is planning on updating the roster in late Mar/early Apr so please check to make sure info is up-to-date.

Activities: Dave and Susan Jones.

Past and Upcoming Activities. Feb 10: SCVC's 64th birthday celebration - the tour to San Martin at Christina and Rob Barnard's home was a short and muddy tour according to some members. There were 30 families and one guest and no sheet cake was leftover. Thank you Christina and Rob!

Mar 8-10: CCRG meet - travel to Clovis. Twenty-three families will be on tour. Don Cole to travel Thursday with nine families. The Friday group will stop in Los Banos, then on to 99. Plan to arrive by noon at Clovis.

Mar 17: St. Patrick's Day: Alternate local tour to Cobra Experience museum. Roger Griffin organized this tour (\$12 for 62+ yrs). Meet in Milpitas, in front of the Safeway Center by Peet's Coffee. Meet at 8:30, lv at 9am. Plan on a picnic lunch by the river after the museum (or visit a restaurant in Martinez).

Apr 13: Joint tour with Grampa Chapter of Salinas/Monterey. The club will travel by way of San Juan Bautista via mostly back roads. Will visit a train museum and then have lunch at a park. SCVC members are invited to bring potluck items such as snacks, salads and dessert. Grandpa Chapter will provide BBQ.

Apr 14: All Ford's Swap Meet

May 3-4: Lake County A's 26th Annual Spring Opener. Host hotel is Konocti Harbor Resort

May 18: Tour to Niles with vintage bus and silent movie museums

May 19: Friendship Day tour. Bill Bratt is hoping to obtain a lower price for pre-war cars

May 24-26: NCRG Sagebrush Classic Round Up in Carson City, NV

Jun 8-9: SCVMTC Annual Speedster Endurance Run and Lowland Tour. Registration open now at www.SCVMTC.com

Jun 24: Tour to celebrate 50th Anniversary of family ownership of the Enderby's Model A. Drive to the Alpine Inn. Reach out to Kevin Enderby if you are interested

Seminars:

Fun/Fashion Seminar: Liz Marshall/Liz Ng - Mar 23 Making lace era pins (and clips) at Barretts. Apr joint seminar on hubleys at Eldertons. May 11 fashion seminar and/or craft activity at Barretts. Please contact either Liz's if you can host a fun & fashion in Jun, Jul or Aug. The Cross family volunteered to host in the near future. They live in Milpitas.

Tech Seminar: Rich Campbell - Mar 23 Radiator prep for summertime (will also cover best antifreeze, thermostats, 2,4,6 blade fans, engine cooling in general; see an old radiator taken apart). Typically, tech seminars are on 4th Saturday but they are moving around in the next couple of months. Apr hubley seminar: alignment tool for front wheels; tips on how to make them faster.

Librarian: Karen Larsen and Rob Keefe. Will bring some books to the next fun fashion seminar as well as for the tech seminars

Webmaster: Wayne Innamorato. Website has been updated for future tours. Click on links and info will be available

Facebook Coordinator: Shauna McGuiness (not present). Some non members are trying to post to Facebook

Sunshine Program Coordinator: Gina Anderson is happy to report many Feb recipients are doing well - Jeannie Day is home, Jay Day is better, Dave Jones is doing well. Sandy Casalino has been in and out of the hospital in the past month. A card was sent to her again. This month Will Lancaster has been sick. Gina will be sending Don Cole a card for his back.

Vest Material: Vicky Wildman has had no request for vest material. Keep vests in mind for the wonderful upcoming events occurring.

Participation: Chuck Elderton. The Feb mtg had 56 member families and a guest in attendance. There were 55 individuals at the birthday party with 19 Model As present. The seminars drew good attendance with 21 families at the fun/fashion and 35 attending the technical seminar.

MAFCA & MAFFI: Chuck Christensen. National meet in New Mexico in June. MAFCA is working with MARC

(Model A Restorers Club) to publish the next update to the Model A Ford Restoration Guidelines and Judging Standards.

NCRG: Jill Barrett (no report).

Unfinished Business: Mark Barrett asks for advertising and historian volunteers to please reach out if interested. Credit card/electronic payment use was researched. Thanks to Larry Rosenthal, Doug Anberg and Wayne Innamorato, however the Board voted not to make changes at this time. The sentiment was that currently volunteer positions are not easy to fill and more responsibilities may hinder recruitment.

New Business: none.

New Cars: none.

Trophies:

Hard luck trophy: "How did your car let you down?" None. Edsel trophy: "How did you let your car down?" Kenny Cross forgot to cover his Roadster before the rain. His seat was ruined.

Good Samaritan trophy: Richard Campbell thanks Kelly Bybee for installing an engine. Kelly Bybee thanks Ted Kafer for electric wiring. Richard Campbell thanks Don Pedrazzi and Hans Peters for their advice and tools for display in the seminar and also thanks Don Cole and John Seabury for giving the seminar. Jeannie Day thanks members for sending her cards for her knee surgery. Kenny Cross thanks Brian McGuiness for helping him with his car. John Seabury thanks Gene Mandere, Glen Wildman and Ray Fontaine for helping him find a straight axle. Ray Fontaine thanks Ted Kafer for helping him tune up his Model A. Laurie Elliott thanks ladies who brought dresses to the seminar and Judy for the dress rack. Mike Stevens thanks Ted Kafer and finally Jon Kaefer thanks Rich Campbell for getting his motor started and bringing tools.

Good of the order: Doug Anberg wants to remind us there are videos of tech seminars (over the past few years) posted on our website. Glen Wildman announced there is to be a 2nd annual BBQ at Mt. Madonna park in August. The Cilkers have a vase from a 2008 Texas national tour that needs a new home.

Mar birthdays and anniversaries: Gwen Campbell. (Where are the other Mar birthday babies and couples celebrating anniversaries? Send them in).

Next board mtg: Mar 26

Next general mtg: Apr 2

Adjournment motioned by Rich Campbell and seconded by Jay Day at 8:26pm.

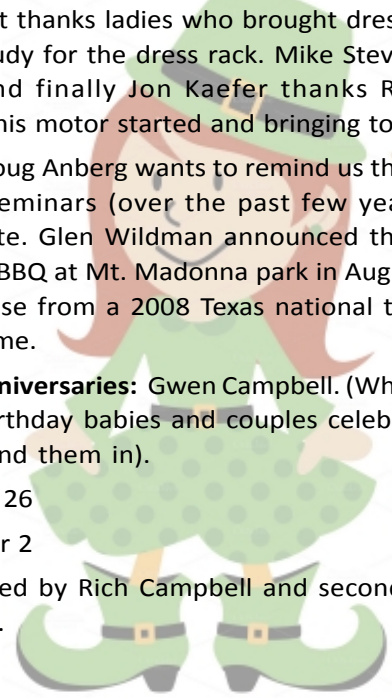

2024 SCVC Club Activities are shown in Bold.

Mar 5, Tue, SCVC General Meeting on ZOOM, 7:00pm.

Mar 8-9, CCRG Jamboree, "A's & More in 24" sponsored by the Sierra Club of Fresno/Clovis area. www.sierramodelafordclub.com. Dave Jones will be leading our group to the meet. Meet at McDonalds, 5508 Monterey Hwy, San Jose, at 7:30am, leave at 8:00am.

Mar 17, Sun, Freeway Tour to The Cobra Experience Museum in Martinez. After we tour the museum, we have identified a local park if you wish to bring your own brown-bag lunch (weather permitting). Also lunch available at various local eating places. Meet in front of Peet's Coffee & Safeway, 627 E. Calaveras Blvd, Milpitas, at 8:30am leave at 9:00.

Mar 23, Sat, Tech Seminar, "Prep Your Radiator for Summer". 10:00am at Rich Campbell's, 1310 Olympia Ave, Campbell.

Mar 23, Sat, Fun/Fashion, Making Lace Pins led by Liz Ng. 9:30am at Barretts, 2860 Rustic Drive, San Jose.

Mar 26, Tue, SCVC Board Meeting on ZOOM, 7:00pm.

Apr 1-15, Solar Eclipse Tour to Texas, if interested, RSVP to Janet Lange, jlpl43@sbcglobal.net, stay tuned.

Apr 2, Tue, SCVC General Meeting on ZOOM, 7:00pm.

Apr 14, Sun, All Ford Swap Meet, 1600 Dell Ave, Campbell, CA

May 3-5, Lake County A's Spring opener. Hosted at Konocti Harbor Resort in Kelseyville.

May 4, Sat, Famoso Swap-o-rama (new home of Bakersfield Prewar Swap), Famoso Drag Strip, McFarland, CA

May 19, Friendship Day hosted by Mid-Peninsula Old Time Auto Club, 441 Seaport Ct., Redwood City.

May 24-26, NCRG "Sagebrush Classic" in Carson City, NV, more later.

June 2, Sun, Auburn Swap Meet at Gold Country Fairgrounds, Auburn, more info when available.

June 8-9, Santa Clara Valley Model T Club Endurance Run and Lowland Tour.

June 23-29, MAFCA National Convention, "Southwest "A" Ventures" sponsored by the Southwest Model A's, Event being held in Ruidoso, New Mexico. www.southwestaventures.com



COMING ATTRACTIONS

SATURDAY MAY 4, 2024

FAMOSO SWAP O RAMA

DRAGSTRIP
BAKERSFIELD - CA
+ CAR CORRAL
+ VINTAGE CAMPER DISPLAY
+ SHOW AND SHINE



CLASSIC CAR AND MOTORCYCLE SWAP MEET

CALL (844) 346-4876 TO RESERVE YOUR SPACE

WWW.FamosoDragStrip.Com - 33559 Famoso Road Mc Farland, CA 93250

SATURDAY MAY 4TH 7AM TO 5PM
NO MOVE-IN AFTER 7AM ON SATURDAY

LARGE SWAP SPACES | PAVED CAR CORRAL | COMMERCIAL VENDORS | GASOLINE ALLEY | AUTOMOBILIA

TURN THOSE OLD PARTS INTO CASH!

<p>SWAP SPACES 30'X60' \$60.00 PRE-REGISTERED Friday 8am to 5pm-Sun 7am-5pm Saturday 7am-5pm \$75.00 ON FRIDAY MOVE-IN DAY & DAY OF SWAP MEET 2 WRIST BANDS CAMP IN YOUR SPACE</p>	<p>CAR CORRAL PARKING SPACE \$40.00 PRE-REGISTERED Friday 8am to 5pm-Sun 7am-5pm \$50.00 ON FRIDAY MOVE-IN DAY & DAY OF SWAP MEET 2 WRIST BANDS CAMP IN YOUR SPACE</p>	<p>RV PARKING \$40.00 PRE-REGISTERED Friday 8am to 5pm-Sun 7am-5pm \$55.00 ON FRIDAY MOVE-IN DAY DRY CAMPING ONLY 2 WRIST BANDS NO OPEN FLAMES</p>	<p>COMMERCIAL SPACES PLEASE CALL THE FAMOSO DRAGSTRIP* TO RESERVE YOUR VENDOR SPACE 4 WRIST BANDS Friday 8am to 5pm-Sun 7am-5pm Saturday 7am-5pm \$25.00 FOR ADDITIONAL WRIST BANDS</p>
---	---	---	--

\$15.00 ADMISSION FOR ADULTS, 12 YEARS & UNDER FREE! GATES OPEN SATURDAY AT 7:00 AM

Budweiser
KING OF BEERS®

Model A Ford Club of America
2024 National Convention
in Ruidoso, New Mexico



June 23rd to 29th, 2024
at the
Ruidoso Convention Center



Host Hotel: MCM Elegante Ruidoso

- Door prizes
- Car Games
- Raffles
- Tours

SouthwestAventures.com
Sponsored by "Southwest Model A's"

FRIENDSHIP DAY 2024
Sunday, May 19th / 8am-2pm
441 Seaport Court, Port of Redwood City





Mid Peninsula Old Time Auto Club

www.MPOTAC.com

We are the Bay Area's longest running family friendly car show. The Mid-Peninsula Old Time Auto Club (MPOTAC), began in 1960 and Friendship Day started in 1963 (sixty years ago).

Sunday May 19th, 2024

2024 SAGEBRUSH CLASSIC



MAY 24, 25, 26
FUJI PARK
Carson City, Nevada

★ Banger A's ★ NCRG ★ MAFCA ★

SCVC BIRTHDAY TOUR TO THE BARNARD ESTATE IN SAN MARTIN

February 10, 2024: We were blessed with a beautiful day of blue sky and sunshine for a nice tour of the southern portion of Santa Clara County. A long line of Model A's headed out through the Almaden Valley and made our way past Calero Reservoir and Uvas Reservoir winding through the hills and back roads. One of our newest member couples, Rob & Christina Barnard, offered to have the club gather at their spacious home and property in San Martin. There was plenty of space to park 19 Model A's and several modern cars. We enjoyed our brown bag lunches around the pool and on the deck followed by cake celebrating SCVC's 64th anniversary (thanks to Dave & Susan Jones, our wonderful tour planners). Our hosts supplied much appreciated coffee and tea. A few of us were lucky enough to meet the resident roosters and hens who were kept penned up so that we wouldn't have a chicken friend in our laps while we ate. The club members enjoyed the time spent together and there was lots of conversation and camaraderie. Many thanks to Rob & Christina!

Jane Grometer



Bit of a country convoy.

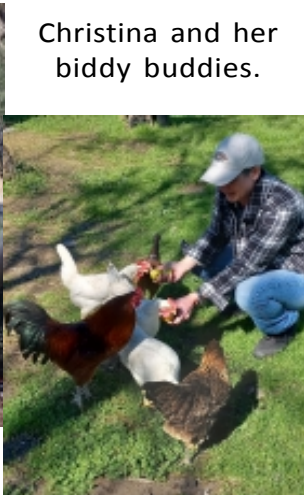

Christina and her biddy buddies.



What's a country tour without a little mud.



Poolside party, very orderly, no one pushed or fell in.

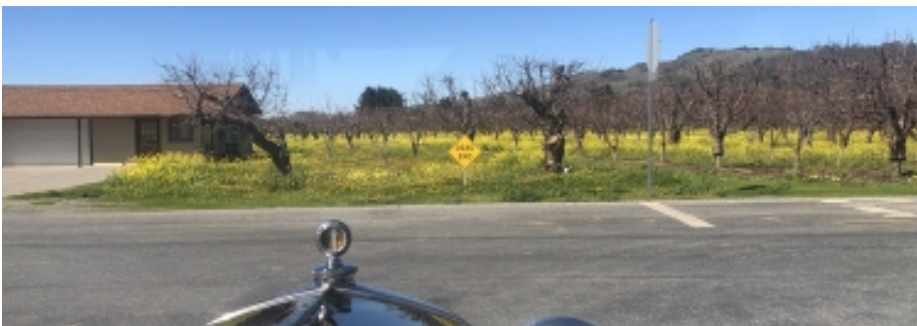

On the way home, stumbled on this scene from days gone by. page 7



64th Anniversary Cake!!!



OUR FLAT-HEAD FORD A FAMILY VISION FULFILLED

by Kevin Enderby

I think I've been to every Palo Alto Concours. But I don't really remember the early ones since I likely came on my dad's shoulders as a toddler.

The Enderby family moved to Palo Alto in 1961 and first lived on Oregon Avenue, before it became Oregon Expressway. One day back in the 10s, while the family was driving home though Los Altos, my dad spotted a 1929 Ford Model A roadster for sale. It was in okay shape, so he bought it. After towing it home, dad got it running. A few years later I took my driver's test in it just for fun when I got my first driver's license.

I think when dad first bought the Model A he hoped his boys would eventually restore the car and bring it to the Palo Alto Concours. But while we were growing up, Dad bought a variety of nice, used sports cars. Although we had "regular" cars, the Model A always had a spot in the garage. After all the boys had moved out, it looked like the Ford was going to get the boot when dad got mom a new Caddy, and she wanted the space in the garage next to dad's Porsche. So I bought the Model A from my dad, as I could not bear to see it leave the family.

Our Model A was in just average shape the first 26 years we owned it. Finally in 2000 I started restoring the Ford. It was a ground-up restoration, but being a true car guy and very much wanting to keep the sense of history, I was very careful not to over-restore the car. My hope was that when it was finished, the car would remain authentic and not some piece of art.

No aspect of the car hobby upsets me more than to go to a car show and see a grossly over-restored Model A get an award. Such car events are a disgrace to the history of cars, and that history is lost to the generations that follow. But it takes self control. It's tough to resist the temptation to make the car "better" -- like explaining to a painter or plater/polisher that you really don't want their very best work for every piece of the car. I found this out when my plater incorrectly polished the back sides of my original bumpers. After two attempts to recreate the original finish, I finally had to put those overdone parts aside and get another set.

Finally, 3.1/2 years later, Dad drove our newly restored Model A to the 2004 Palo Alto Concours. It was a very satisfying day for us, the culmination of a long-delayed project that left me feeling like I'd fulfilled a family obligation.

While the Ford is a very nice car now, it still gets driven regularly. In fact, it's my favorite car to run errands and take my volleyball nets to play at the Stanford Oval on weekends. Dad raised us to believe that toys were meant to be played with, and cars were meant to be enjoyed.

I've tried to carry that lesson over to the other cars I own. Today on the Concours field you'll find me organizing the judging for the Ferrari classes. *Kevin Enderby*

MICROMETERS AND MEASURING TOOLS

February 24, 2024: Lots of folks interested in this one, big crowd in Rich Campbell's carport. The subject for the day was how to make all those measurements on a model A engine in particular. Don Cole gave a good demo on what tools it takes to measure flatness on a Model A block or head. He also had a great tool for measuring wear on brake drums. Then John Seabury addressed micrometers and how to read them to one thousandth and beyond. John had an assortment of tools and demonstrated how to measure crankshaft journals, cam

lift and cylinder bores. Outside mics, inside mics, dial gages, calipers, depth gages all were discussed. Now we all know what to look for at the swap meets.. *Bob M*

SPECIAL THANKS

Special thanks to Don Pedrazzi and Hans Peters for loan of their tools (and the education they gave me)..Also thanks to Don Cole and John Seabury for stepping up with great show and tell. (We learn best from our members). Big Thanks, *Rich C*



Big crowd, all listening intently.



John talking micrometers, notice the fancy on-screen image while he talks.



Don Cole talking brake drum measurements.

FEBRUARY WOMEN'S SEMINAR

February 24, 2024: Have you wondered what Era dresses look like, how to find them, and how to get the right fit?

If you missed the latest Women's Fashion Seminar, many of your questions would have been answered. 20+ of our fellow SCVC ladies met at Judy Rinaldi's to answer just these questions, and more. A movable clothes rod was set up in Judy's living room. Many members brought dresses which were appropriate to our era, to hang. Laurie Elliott and Jill Barrett selected one at a time and elaborated on why they were our era. Laurie & Jill discussed styles, sleeves, collar styles, sashes and what occasion a lady might wear them. They even tried to pinpoint the year(s). Most of these dresses were era image found on-line, some, with the labels attached. Jill provided a list of fashion terms you can use to search EBAY or ETSY. We learned you can match clothing colors to MAFCA auto paint chips. I learned what era terms to use when I do an on-line search on EBAY and ETSY. Great job Laurie & Jill.

Susan Colbeck



MODERN COLORFUL COTTONS

PASTORAL CLOTHS GUARANTEED

EXQUISITELY FINE PLAIN 33¢ A YARD Postpaid

ENSEMBLES PERFECTLY PRINTED 38¢ A Beauty Fabric Just for You A YARD Postpaid

Colors That Rival Flower Tints

The very fabric you'll want for making the new, shimmering dresses...
 36V5197—Width, 36 inches. Colors shown. 33¢ A Yard
 Mastion order 36V5007
 White only. Width, 36 inches. Same quality as 36V5007. 27¢ A Yard

Pastoral Cloths Guaranteed Low Colors...
 36V3337—Width, 36 inches. Order by catalog number and pattern number.

How about those prices?



Some early illustrations.

LUCKY ME!

By Laurie Elliott

When I was a teenager, one of my grandmothers died and, by request, I inherited her sewing basket. Along with the spools of thread and cardboard books of needles, there was a funky little tape measure in a metal half shoe case which reads, "Three Feet in One Shoe". Even then it looked very old.

Fast forward a few decades, when I'm trying to put together a housedress/ sewing Fashion entry for judging. In case you don't know, if something isn't in the Fashion Guidelines, the entrant must provide their own primary-sourced documentation.

Is my funky tape measure in the Fashion Guidelines or any other Era magazines or catalogs I own? No.

After the February seminar, Judy Rinaldi handed me a stack of era fashion paper resources - some to copy and return, and some to keep. And if you're guessing that Judy unknowingly provided me the needed documentation, you'd be right. In the booklet of Baird-North Co. World's Largest Mail Order Jewelers and Gift Shop, 1928, my tape measure is right there along with thimbles and scissors. I'm so happy!

Thank you, Judy, for not only hosting the February seminar, but for giving me your wonderful little jewelry and gift items catalog. You are a gem.

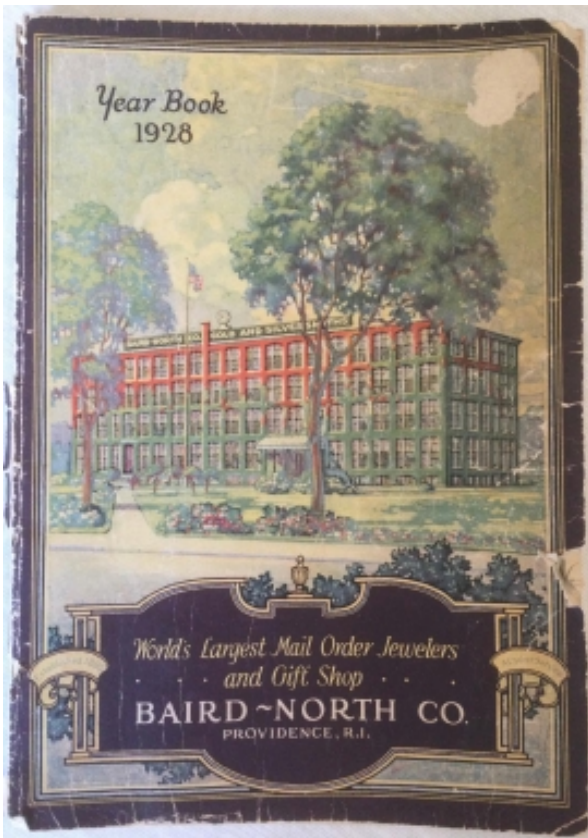

MAFFI MINUTE (MODEL A FORD FOUNDATION, INC.)

The Trustees are already planning Model A Days 2024! So far it looks like a candidate for the First Start Event (barn find which hasn't been run in a few decades) has been located. And, the report from the Gilmore Auto Museum is that one of the Event Centers will be finished in time for Model A Days, which will be nice for our Model A visitors.

Other news is that Model A's donated to the museum to be sold for the Model A Museum Expansion are getting checked over and repaired so they are roadworthy to sell. Our hardworking team of volunteers devotes Thursday evening to getting the Model A's in "sale ready" shape.

- 1. One Model A Tudor (1929) is on the sales floor already.
- 2. Another 1928 Tudor has had Trustees and friends repairing brakes, gas gauge, and a gas tank, to name a few, so it should be ready shortly
- 3. A 1929 Fordor Blindback is also in the queue for roadworthiness work.
- 4. And there are two 1928 Phaetons that we anticipate will be available to sell in the coming months.

Please contact Jerry Dennany, jerrydennany@gmail.com or John Begg, jwbegg@gmail.com for information about these cars or if you have a vehicle you would like to donate to be sold for our expansion fundraising program.

Many of you have been following our Save the Bus project (school bus) and although the bus has taken longer than we anticipated, things are coming along nicely now. The sides are up and all 4 fenders have been installed as well as the bumpers. There's lots of sandblasting, and just plain sanding and priming going on now. Things are getting exciting at Save the Bus Headquarters!

As always, we appreciate your support as we move forward with fundraising. It's all of you that make the Model A Ford Foundation Inc. Museum so awesome.

Cindy Ellenbecker, Model A Ford Foundation, Inc. Trustee/Secretary



I don't know about you but time sure seems to slip by faster as I get older. I remember how time seemed to drag by when I was younger. Day to day activities seemed to move along at a snail's pace. I've finally reached the age where I have trouble keeping up with the world around me. Either I have too many things going on or I'm just not as efficient as I once was. Since I've spent 50 years of marriage trying to convince my wife that I'm perfect it must be that I have too many "things" happening in my life. I guess having too many activities is better than having none but sometimes it sure gets hectic.

I do have a couple of items to mention that are time sensitive. If any of the following item's appeal to you now is the time to be acting on them. If you are like me, they will be in our rear-view mirror before we know it.



1. Now is the time for you to decide if you are interested in participating in MAFCA's leadership as a National Director. Information is available on the MAFCA website at: <https://www.mafca.com/elections.html>. Additionally, each Director is available to answer your questions and help steer you in the right direction to run for office. Having a sufficient number of volunteers to run our club is essential to MAFCA's future. There is no better time to get involved than now.

2. Our 2024 MAFCA national convention, Southwest "A"ventures, is scheduled for June 23 – 29 and is being hosted by the Southwest Model A's. They have planned a great list of activities and are working diligently to put together a great outing. Check their webpage: <https://www.southwestaventures.com/> for information on registration, including the registration forms, convention clothing items, raffle items and access to purchasing raffle tickets. The registrations are steadily coming in and we're sure to have a great convention. Sounds too good to miss so start your planning now!

3. In prior years MAFCA has clearly supported the concept that youth are essential to the Model A hobby's future and chapters are the means to introduce youth to the hobby. Two great organizations: The Model A Youth Restoration Award, MAYRA, provides financial support to youth whose interest in the hobby is demonstrated by their efforts in restoring a Model A and the Model A Youth Scholarship Fund provides financial support to assist children and/or grandchildren of any MAFCA/MARC member in pursuing their undergraduate education, whether it be a state university, college or technical school. Both organizations have website links on the MAFCA website under Youth, Grants and Scholarships. Establishing club activities that invite youth participation is a fundamental key to turning our youth into lifelong hobbyists. May of each year has been designated as Model A Youth Month. Now is the time for chapters to complete their planning and begin to publicize their event. I look forward to reading about the many different ways our chapters are involving our youth in the hobby.

It's shaping up to be a great year in the Model A hobby. On a national level we have a MAFCA presence at the annual MAFFI Model A Days, MAFCA's national convention in Ruidoso, NM, MAFCA's annual award banquet in Salt Lake City, UT and a MAFCA tent and seminars at Hershey. Throw in a few local state tours along with some local club tours and everyone call fill out their calendar with Model A touring events. Looks like I'm going to have a big mileage year, I hope you do as well.

"See you down the road."

Robert Bullard, 2024 MAFCA President



SHADE TREE MECHANICS



OVERFLOW BOTTLE

Here is the scenario, it's hot, it's high altitude, you are climbing a mountain. The wife is very nervously watching the temperature gauge. Finally happens, you boil over, and pull over amidst a cloud of steam to let everything cool off.

So, how do folks prevent this scenario, and how do they deal with it if it does occur? First, my own personal experience. I have a 3 quart overflow bottle. My radiator cap is sealed, but the overflow tube is vented to the atmosphere, regular Model A radiator with 10 fins to the inch. I run 50/50 antifreeze which has a boiling point of 223 degrees F at sea level. Even with that high boiling point, I have on occasion boiled the car, again mostly in high altitude, high temperature situations. What I have found is that 3 quarts is about the maximum amount of coolant that can be expelled when a steam bubble forms. When the first 3 quarts is forced out, the path is clear for the steam to exit without taking anymore coolant with it. Now, I do carry a spray bottle of water, and I do not turn the engine off. Shoot the radiator with a few shots from the spray bottle and it is amazing how quickly the boiling ceases. And, when the steam bubble collapses, you can watch the level in the coolant recovery bottle go down very quickly as the coolant flows back into the engine. And, it is not immediately necessary to add coolant, some has been lost, but enough has been saved to keep on going. So, away we go, maybe a little less aggressive on the throttle

I guess if I wanted to move a little farther into the modern world, I would change to a pressurized radiator. Lots of folks have done that, and installed one of the vertical tube recovery tanks which are too small for my liking. Using a 4psi radiator cap on a Brassworks radiator raises the boiling point by 12 degrees.

So the moral of this story is: as many fins per inch as you can get, 50/50 antifreeze (also prevents corrosion), sealed system, nice big overflow bottle, and a good temperature gauge so that you know when to back off on the throttle.

See you on the road, watch out for those hot hills. (and vapor lock, that is another story.)

Bob Meneely



Elegant but small capacity.

Nice and shiny and larger

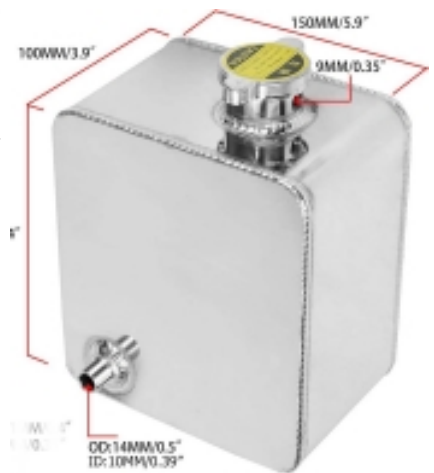

Large and cheap and ugly

Ford did have a design for an air cleaner as shown by the patent below. I think that the most interesting statements in his description of what this air cleaner is all about are these.

Page 1-line 12 "This air cleaner is therefore well able to last the life of the engine with which it is used,"
Page 2-Line 57 " although the air cleaner may be readily removed this is seldom necessary because the dust particles which are separated from the air do not collect in the cleaner" *Chuck Christensen*

May 5, 1931.

H. FORD
AIR CLEANER

1,803,751

Filed Aug. 28, 1929

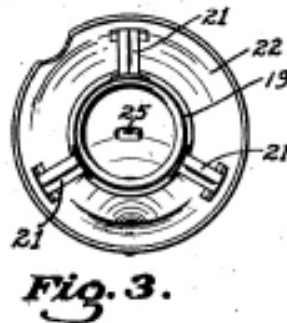
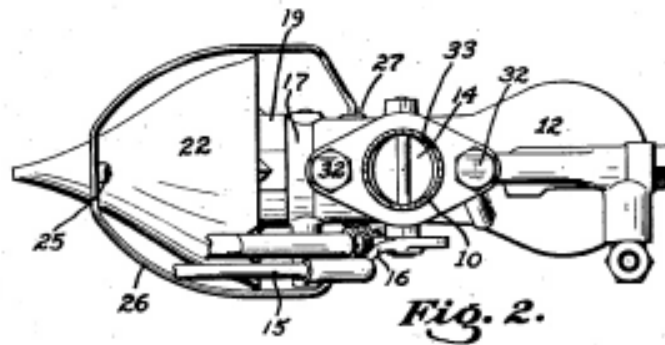
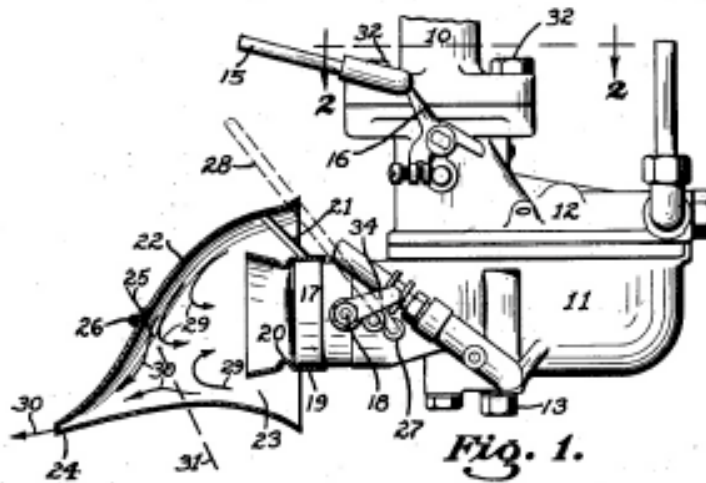

INVENTOR:
Henry Ford.
BY
Chas. Davis
ATTORNEY.

20 years ago. March was a combined Seminar and Crab Feed at Bill Rose's shop in Livermore. Also, an overnight tour to Chowchilla was planned. It was 224 miles thru the beautiful Altamont and San Joaquin Valleys.

40 years ago. Roger Griffin was president of SCVC in 1984. The fourth biennial Santa Clara Valley All Ford Picnic was held at Fanborn Park. The activities included a fun rally and field event. There were Model A's, Model T's, early V8's, Mustangs and many more Fords. It was a great Ford day.

60 years ago. Well, 1964 started off with a great deal of club activities. First, the club lost its meeting place. Second, the club lost its newly elected vice president. Third, the club newspaper lost its editor. But good news, everyone pulled together and all was fixed.

FROM WAY BACK WHEN



Charter Members Bill & Edie Jones



Everyone remembers the picture, but do you remember the name of the movie?

**A WHISKERY KISS
FOR THE ONE
YOU ADORE
MAY NOT MAKE HER MAD
BUT HER FACE WILL BE SORE**



**MUSINGS
OF
VAGABOND
GREEN**



I find I have inventory problems. Maybe this is just an old guy thing, see if this rings a bell. The other day, I needed a little part for the A, so I looked through my stash to see if I had one. I made a cursory search in all the logical places, couldn't find one, so I decided I need to order the item. So now, what is the correct name? You must have either the name that the vendor uses or the exact part number. This takes 5 minutes, but finally, there it is. Holy Cow! Is that the current price? Okay, gotta have it, put it in the shopping cart. Hit the order button, whoa, the shipping cost is more than the part. What the heck ever happened to first class mail or parcel post. Have you noticed that now the preferred mode of shipping at the US Post Office is now called Ground Advantage? Whose advantage, not mine. Okay, I try to hold off until I have more items to order, to defray the shipping cost a little bit. Finally I even add a couple items that I don't really need right now but might need in the future, grit my teeth and place the order. Now I find that the shipping time seems to be longer than it used to be. What the heck? But, eventually, the part arrives and gets installed, problem solved. Of course, the other day, my toe caught the corner of a little box under the workbench, and when I pulled it out, there was the part that I needed. I gotta get organized one of these days!

**IT SEEMED LIKE A GOOD IDEA AT THE TIME
(from 1914 Popular Mechanics)**

**CIGARETTE HOLDER RELIEVES
AUTO DRIVER OF BURDEN**

A device recently has been patented which relieves the driver of an auto-

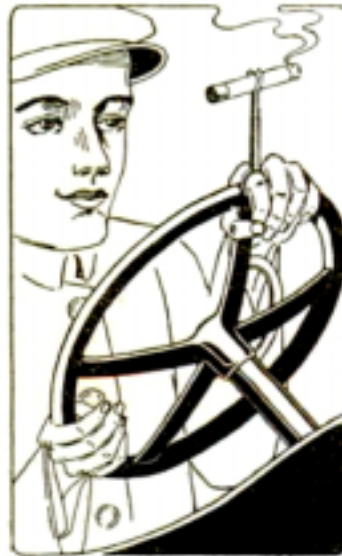

mobile of the burden of holding his cigarette while driving. A metal frame with U-shaped clasps at either end grips the cigarette with one clasp, while the other end is fastened tightly around the finger. This leaves the hand entirely free for manip-

ulation of levers, etc., while maintaining the cigarette in convenient position for smoking.

A CHUCKLE A DAY.....

Blonde at the Super bowl

Of all the blonde jokes, this one has to be one of the best -- because it makes football make sense!

This guy took his blonde girlfriend to the Super Bowl game They had great seats behind their team's bench. Right After the game, he asked her how she liked it. "Oh, I really liked it," she replied, "especially the tight pants and all the big muscles, but I just couldn't understand why they were killing each other over 25 cents." Dumbfounded, her boyfriend asked, "What do you mean?" "Well, they flipped a coin, one team got it and then for the rest of the game, all they kept screaming was... 'Get the quarterback! Get the quarterback!' I'm like...Hell000000? It's only 25 cents!"



CLASSIFIEDS

Stuff for sale or trade. Submit your ads to Bob Meneely, 26044 Duval Way, Los Altos Hills, CA 94022, (650) 948-9301, rmnly@yahoo.com . Ads will be run for 3 months unless cancelled.

FOR SALE 1931 Ford Model A Deluxe Coupe, \$16,000

1931 Model A Deluxe Coupe. All original with new mechanical brakes and drums. Model B engine. LED brake and turn signal added. Comes with 1935 powder coated rims and new tires with spare. Also have original rims and tires for the car.

Contact Issa Ajlouny, 408-569-4772

01/24



FOR SALE: 16", 17", 18" Ford spoked wheels from the 30's. \$40 ea. Bob Meneely 650-948-9301 02/24

FOR SALE: Hubley Model A Phaeton kit, sealed original Hubley, \$50;

Hubley Model A Roadster kit, open box, original Hubley \$45;

Hubley Model A Station Wagon kit, open box, original Hubley \$45.

FOR SALE: CarryKing Metal Trunk, \$125; Ray Fontaine, 408-258-0186 03/24

Ted Kafer, tkafer@sbcglobal.net, 408-866-2533 03/24

Model B Engine for Sale: Completely rebuilt with new Babbitt bearings and sleeved to standard. Come see it run on the test stand in our shop. Includes Snyders Touring Cam, counterbalanced "C" crankshaft, Burtz 6.5 to 1 Model A high compression head with improved water flow. Has Lighted Model B Flywheel and rebuilt pressure plate, new clutch plate. Outright \$5700 with no core. Less if you have a good core. Go to www.amuffler.com under "For Sale", for a link to the video showing the engine running. Does not include manifolds, carburetor, generator, starter or distributor.

Joe Davis, Aries Limited,

16 West Jackson Street, Medford, OR 97501

650-279-6609 www.amuffler.com

03/24

page 18



FOR SALE: Late 1931 Ford Model A Steel Cab Truck, \$15,000 obo

1931 Ford Model A Steel Cab Wide Bed Pickup Identification No. DMV50222CA

This late model 1931 Steel Cab Pickup has gone through a complete mechanical restoration in 2021. The restoration includes a 50+ hp Burtz inline four-cylinder engine with less than 1,000 miles, two-barrel Weber Carburetor, Brierly Cam (C- Grind), 12V electrical, rebuilt four-speed F150 manual transmission, rebuilt F100 pickup steering, four-wheel hydraulic brakes and Ford spoke wheels with fresh powder coat paint.

This handsome Steel Cab Pickup has been in the collection of a California Model A family since 1976. The Truck currently resides in Virginia where the owner has maintained it fastidiously, participating in Washington DC area car shows and parades.

Finished in Black, it has the standard Black artificial leather interior. Built in late 1931, it has all the very late Model A features, including the indented firewall and re-designed fuel tank. Steel Cab, Wide-Bed Model A Trucks seldom appear on the market much less with a Burtz engine. This late-model Pickup represents a rare opportunity to acquire a great example of this very desirable model. For Inquiries: Call Paul in Virginia at 703.627.1324 or WhatApp Sean at +260 97 4622275 02/24



FOR SALE: Model A parts

2 Simmons Model A carburetor cast iron bodies with some parts - \$40.00

Slant Window passenger side window regulator (A-164202) good condition, 1 threaded hole needs repair. \$125.00

Generator & Starter bands both 10/1929 (K10) plus 9/1929 (9K) distributor top plate. \$35.00

6 bladed plastic fan and steel hub. \$45.00

1 - A-7523-R spring (clutch pedal) (2 loop) NOS. \$30.00

Pair of 30-31AA short running boards in good condition, slight curve and no worn through dimples. \$75.00

4 original shock link bodies - \$20.00

1 - Brake pedal (11/1930 on) stamped steel ribbed surface, extremely nice, could be NOS. \$50.00

1 - AA-17697-B (10" long) review mirror bracket (cast aluminum from an original). It is the rough casting and needs finishing. \$75.00

2 - AA-17698 (14-11/16" long) review mirror bracket (cast bronze from an original). The rough castings need finishing. \$200.00-both

AA Long Wheelbase coupling shaft (AA-4815-C) - \$50.00

1932 to 34 NOS B-3575 Sector (steering worm) - \$85.00

Free - round Model A Vase from 2008 Dallas Meet. Pictures on request

Bill Cilker 408-234-5868

02/24

FOR SALE: Early 1930 Model A Coupe project car, needs to be finished (paint and assembly). Body and frame in good condition. Currently in primer. All modifications and fabrications are complete. Comes with 1930 plates. Bill of sale only. Needs to be verified for title. Converted to hydraulic brakes. Converted to 12V system. Engine has been rebuilt with Cragger overhead valve modification and dual Stromberg carburetors (not started). 16" wheels. Tires are new, but have been sitting. Drop front axle. SoCal Speed Shop reversed eye rear lowering spring. Comes with original engine block, and many spare parts. Front seat has been re-upholstered. Rumble seat is just springs. Comes with brand new wood kit. Windshield and all glass has been replaced. \$15000. Call Nick at (408)313-8948 or email nkmandere@gmail.com 03/24

SANTA CLARA POWDER COATING INC.

"Let Us Fix It Like New"

RESTORATION OF PATIO FURNITURE

- INDUSTRIAL - COMMERCIAL - AUTOMOTIVE

- SAND BLASTING - SLING REPLACEMENT - REPAIR & PARTS

- CAST ALUMINUM - WROUGHT IRON - VINYL STRAPPING

800 ALDO AVE. SANTA CLARA, CA - 408-845-9100

www.scpowder.com



JOHN GUERRA

1600 Dell Avenue, Suite A, Campbell, California 95008
 408-378-1935 • Fax 408-866-1934 • 1-800-532-1932
 Email: allford@jps.net • allfordparts.com

ARIES MUFFLERS & PARTS

ORIGINAL MODEL A FORD EXHAUST SYSTEMS
 MADE PRECISELY TO THE FORD DESIGN

ALSO STATION WAGON TAIL PIPES AND
 FORDSON TRACTOR MUFFLERS(1917-1936)

AMUFFLER.COM

JDAVIS@AMUFFLER.COM
 650.279.6609

ARIZONA MODEL A, L.L.C.

- NEW PARTS
- USED PARTS
- SERVICE
- RESTORATION

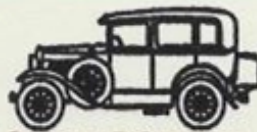

SAMUEL P. GUTHRIE

HOURS: TUES - FRI 9-12, 1-5, SAT & EVES BY APPOINTMENT
 15838 S. GILBERT RD., CHANDLER, AZ 85225
 (480) 782-0266

BRATTON'S ANTIQUE AUTO PARTS

YOUR SOURCE FOR QUALITY
 MODEL A FORD PARTS
 USING OVER 90% U.S.
 MADE PARTS SINCE 1976



800 255-1929 Phone
www.brattons.com
 800 774-1930 Fax
 1606 Back Acre Circle
 Mount Airy, MD 21771

Displayed are some of the parts we make using the FORD Blue print to ensure the correct size, shape, metal and heat treating.
 Be sure you use our Quality parts when working on your Model A.



FREE 180 page illustrated Model A Ford parts catalog containing over 4,000 parts with full description and pictures of each part with your order.



1928-48 FORD CAR & TRUCK

CWMOSS.COM - 800.322.1932

Gaslight Auto Parts since 1962

1909-48 FORD Parts Model A, T, & V-8 Parts

800.242.6491 www.gaslightauto.com 1445 S. US Hwy 68, Urbana, OH 43078

Mike's "A" Ford-able Parts

Mike Butcher



124 Model A Drive, Maysville, GA 30558 email: mike@mikes-afordable.com - www.mikes-afordable.com Fax: 706 652 2492 - Phone: 706 652 3866 1 888 TRY MIKE (879 6453)



Specialising in 1928 - 1931 Model A Ford Parts

MM MITCHELL MANUFACTURING



Steve & Cyndi Mitchell

Mitchell MFG.

530-458-4500 800-859-2088

www.mitchelloverdrivemfg.com mitchmanfc@frontiernet.net

MODEL A FORD SYNCHRONIZED-TRANSMISSION VINTAGE CAR OVERDRIVES FORD OVERDRIVES/UNDERDRIVES 1928-1948

P.O. Box 925 1157 Parker St. Colusa, CA 95932

EVERYTHING FROM A TO Z!



FREE CATALOG U.S.A. Only



888-262-5712 snydersantiqueauto.com

THE WORLD'S LARGEST SUPPLIER OF 1909-31 FORD PARTS!

"ONE MILE AHEAD" Smith and Jones ANTIQUE AUTO PARTS SPECIALIZING IN MODEL A AND MODEL T PARTS 60 Wisconsin St., W. Columbia, S.C. 29170

Quality Parts • Same Day Shipping • Established 1972 •

Order Desk 1-800-422-1928 1-803-822-4141 • Fax 1-803-822-8477 All Major Credit Cards Accepted



Davin E. Smith

Orders: www.snjparts.com Email: snjparts@gmail.com

McKenna VanDalen Insurance Services license #OM59477

Ruby VanDalen Broker 12368 Saratoga Sunnyvale Rd Saratoga Ca 95070 408-725-1112 Office 408-725-1177 Fax rinsurance@aol.com

HAGERTY®

Let's Drive Together



The Ford Script
P.O. Box 6918
San Jose, CA 95150